

柔性轴承 Flexible Bearing



洛阳盟拓轴承科技有限公司
LUOYANG MONTON BEARING SCIENCE & TECHNOLOGY CO.,LTD.

柔性轴承 FLEXIBLE BEARINGS

柔性轴承内外圈壁厚较薄，安装在凸轮上，工作时能随不同的凸轮轮廓曲线而产生相应的弹性变形的轴承。柔性轴承是谐波减速器的关键部件，使柔轮产生可控的弹性变形。其性能和寿命将显著影响谐波减速器的正常运行。柔性轴承特点是，传动比大并且适用范围广、精度高、空回小、承载能力大、效率高、体积小、重量轻、传动平稳、噪声小、可向密封空间传递运动。

谐波减速机用柔性轴承主要用于谐波减速机，谐波传动变速器包括三个基本构件：波发生器、柔轮、刚轮及柔性轴承。其中柔性轴承是核心部件，变速器通过轴承的弹性变形达到高减速比的性能要求。柔性轴承在工作中，内圈安装在椭圆形的凸轮上，工作中承受循环应力载荷，外圈安装在柔轮上，工作中随凸轮的转动而发生弹性变形，不仅承受循环应力载荷，而且承受交变应力载荷。

柔性轴承通常由滚动体、轴承珠架、内圈以及外圈构成，高碳铬轴承钢为其主要原材料。高碳铬轴承钢具有耐磨性好、热处理变形小、接触疲劳强度高、耐腐蚀等优势，占据我国轴承钢市场近八成份额。高碳铬轴承钢主要牌号包括GCr15SiMn、ZGCr15SiMn、GCr15、ZGCr15四种，其中GCr15在柔性轴承生产过程中应用较多。我国为钢铁生产大国，高碳铬轴承钢产量长期保持增长趋势，这为柔性轴承行业发展奠定良好基础。

由于柔性轴承的内圈与波发生器的刚性凸轮紧套在起。故可视为刚性的椭圆环；滚动体(一般为球)则为通过弹簧与内外圈相连接的具有集中质量的质点；而外圈为弹性薄壁环，其原始曲线为柔轮原始曲线的内等距曲线。与普通轴承相比，柔性轴承具有精度高、承载能力大、轻量化、无磨损、传动比大、体积小等优势，可用于生产谐波传动减速器，工业机器人、航空航天等为其终端市场。



柔性轴承 FLEXIBLE BEARINGS

Flexible bearings for harmonic reducer are mainly used in harmonic reducer. Harmonic transmission includes three basic components: wave generator, Flexspline, Circular Spline and flexible bearing. Flexible bearings are the core components, and the transmission meets the performance requirements of high deceleration ratio through the elastic deformation of bearings.

In the work of flexible bearing, the inner ring is installed on the elliptical cam, the outer ring is installed on the Flexspline, and the elastic deformation occurs with the rotation of the cam, which not only bears the cyclic stress load, but also bears the alternating stress load.

Flexible bearings for harmonic reducer are mainly used in harmonic reducer. Harmonic transmission includes three basic components: wave generator, Flexspline, Circular Spline and flexible bearing. Flexible bearings are the core components, and the transmission meets the performance requirements of high deceleration ratio through the elastic deformation of bearings.

In the work of flexible bearing, the inner ring is installed on the elliptical cam, the outer ring is installed on the Flexspline, and the elastic deformation occurs with the rotation of the cam, which not only bears the cyclic stress load, but also bears the alternating stress load.

These points put forward high requirements for the design and manufacture of bearing inner ring and outer ring and cage, and only a few enterprises such as Japan and the United States can produce it. Luo yang Monton Flexible Bearing has reached the advanced level of design and manufacture of flexible bearings for harmonic transmission. The design of flexible bearing has formed a complete theoretical system, the manufacturing technology of the product is becoming more and more perfect, mature, and the product quality is becoming more and more stable. The 3E series harmonic drive reducer flexible bearing has been successfully applied to the harmonic drive device of "Shenzhou" and series spaceship, which has contributed to my manned spaceflight industry.

Because the inner ring of the flexible rolling bearing is tightly sheathed with the rigid cam of the wave generator. Therefore, it can be regarded as a rigid elliptical ring, the rolling body (generally a ball) is a particle with concentrated mass connected with the inner and outer rings through the spring, and the outer ring is an elastic thin-wall ring, and its original curve is the inner isometric curve of the original curve of the Flexspline.

Harmonic drive transmission consists of three basic components: wave generator, flex spline, Circular Spline and flexible bearing. Among them, the flexible bearing is the core component, and the transmission achieves the performance requirement of high deceleration ratio through the elastic deformation of the bearing.

When the flexible bearing is in operation, the inner ring is mounted/installed on the elliptical cam, which bears the cyclic stress load during the work; while the outer ring is mounted/installed on the Flexspline, and elastically deforms with the rotation of the cam during the work, which not only bears the cyclic stress load, but also withstands the alternating stress load.

Flexible rolling bearing utilizes controllable elastic deformation of the flexible components to transmit motion and power. It has characteristics of large transmission ratio, wide application range, high precision, small air return, large carrying capacity, high efficiency, small volume/size, light weight, smooth transmission, low noise, and can transfer motion to sealed space.

Robot bearing/harmonic drive bearing is a special kind which easily deforms in a reversible way.

It has a very thin outer ring which varies from round shape to oval interatively during its working time.

easily double sealed bearing designed primarily for application of radial load—deep ball grooves also permit application of thrust load in either direction, often used in conjunction with another bearing.

Our company has professional sales and technical engineers who are responsible for providing users with technical consultation, technical services and product technical training on precision bearing information and installation and use. Perfect pre-sales, in-sales and after-sales services constitute a guarantee system for high-quality services, providing users with reliable quality bearing products, and creating a good user experience and rich benefits for every customer.

If you have any questions about our products and services, please contact our customer service department directly.

柔性轴承
Flexible Bearings

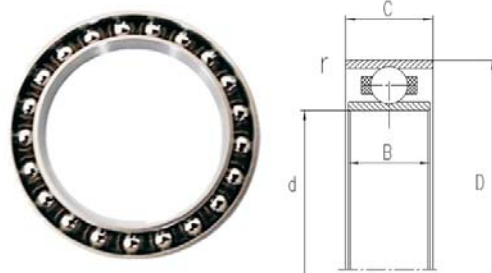

型号	内径	外圈	宽度	额定动负荷	额定静负荷	最大径向变形量	输入转速	输出力矩
Bearing	Inner ring	Outer ring	Width	Dynamic load	Static load	Radial Deformatio	Input rotate	Output torque
Model	ID	OD	B	Cr	Cor	Max. mm	r/min	N.m
3E904KAT2	18.8	25	4	3.75	3.12	0.2	3000	2
3E905KAT2	24	32	5	4.74	3.75	0.2	3000	6
3E806KAT2	30	40	6	7.12	5.83	0.3	3000	16
3E907KAT2	37	50	8	12.63	12	0.3	3000	30
3E809KAT2	45	60	9	12.89	11.55	0.4	3000	50
3E911KAT ₂	57	75	12	14.76	13.18	0.5	3000	7.5
3E812KAT ₂	60	80	13/12	15.51	14.44	0.5	3000	12
3E814KAT ₂	70/71	95	15	22.38	21.57	0.6	3000	20
3E815KAT ₂	75	100	15	26.4	25.67	0.6	3000	25
3E816KAT2	80	110	16	26.4	25.7	0.6	3000	25
3E818KAT ₂	90	120	18	34.7	34.94	1	3000	45
3E822KAT ₂	110	150	24	43.55	45.63	1	1500	80
3E824KAT ₂	120	160	24	57.02	57.75	1	1500	120
3E826KAT ₂	130	175	30	81.59	86.1	1	1500	170
3E830KAT ₂	150	200	30	91.6	102.67	1	1500	200
3E832KAT ₂	160	220	35	115.66	127.59	1.25	1500	220
3E836KAT ₂	180	240	35	130.04	146.47	1.5	1500	250
3E838KAT ₂	190	250	40	139.96	160.42	1.5	1500	350
3E842KAT ₂	210	280	45	173.15	210.91	1.5	1500	400
3E844KAT ₂	220	300	45	181.72	231	1.5	1500	500
3E848KAT2	240	320	48	190.2	231	2	1500	560
3E860KAT2	300	400	60	252	502	3	1200	
3E862KAT2	310	420	60	252	502	3	1200	
3E872KAT2	360	480	72	338	731	3	1200	
1000907AKIT2	35.8	48.2	8	9.93	8.36	0.3	3000	30
1000809AKIT2	45.7	61.8	9.5	12.89	11.55	0.4	3000	50
10008810AKT2	48	63	9.7	12.89	11.55	0.4	3000	50
1000912AKT2	60	80	12	27.19	28.18	0.5	3000	120
F14	25.07	33.896	6.095	4.74	3.75	0.2	3000	8
M14	25.07	33.896	6.095	5.53	4.73	0.2	3000	12
F17	30.3	41.722	6.16	7.12	5.83	0.3	3000	16
M17	30.3	41.722	6.16	8.31	7.35	0.3	3000	24
F20	35.56	49.073	7.24	9.93	8.36	0.3	3000	30
M20	35.56	49.073	7.24	12.63	12	0.3	3000	45
F25	45.212	61.341	9.015	12.89	11.55	0.4	3000	50
M25	45.212	61.341	9.015	16.4	16.58	0.4	3000	75
F32	58.928	79.756	11.81	22.28	20.91	0.5	3000	120
M32	58.928	79.756	11.81	27.19	28.18	0.5	3000	180
F40	71.12	98.171	14.47	26.4	25.67	0.6	3000	200
M40	71.12	98.171	14.47	34.51	33.51	0.6	3000	200

型号	内径	外圈	宽度	额定动负荷	额定静负荷	最大径向变形量	输入转速	输出力矩
Bearing	Inner ring	Outer ring	Width	Dynamic load	Static load	Radial Deformatio	Input rotate	Output torque
Model	ID	OD	B	Cr	Cor	Max. mm	r/min	N.m
F5-Y1	9.8	13.026	2.1	1.2	1	0.15	3000	1.5
F8-Y1	14.22	19.63	3.3	2.8	2.4	0.15	3000	5
F10-Y1	14.5	20	4	2.05	1.46	0.2	3000	0.2
F10-Y2	20.4	27.5	4.5	2.05	1.46	0.2	3000	0.2
F10-Y3	22	30	6	3.44	2.6	0.2	3000	0.6
F11	20.73	27.262	4.6	3.51	3.1	0.2	3000	6
F14-Y1	25.7	33.896	6.35	5.15	4.07	0.3	3000	1.6
F14-Y2	25.5	34	5	5.15	4.07	0.3	3000	1.6
F14-Y3	26.5	35.5	6	5.15	4.07	0.3	3000	1.6
F14-F1	25.07	33.896	4	4.74	3.75	0.8	3000	6
F14-F2	25.07	33.896	6.35	4.74	3.75	0.8	3000	6
F17-Y1	30.3	41.72	6.68	5.15	4.07	0.3	3000	1.6
F17-Y2	33	42	8	5.15	4.07	0.3	3000	1.6
F17-Y3	35.5	48	8	7.13	5.86	0.3	3000	3
F17-Y4	35.8	48.2		7.13	5.86	0.3	3000	3
F17-F1	30.3	41.72	4.6	7.12	5.83	0.9	3000	16
F17-F2	30.3	41.72	6.68	7.12	5.83	0.9	3000	16
F20-Y1	35.56	49.07	8.13	7.13	5.86	0.3	3000	3
F20-Y2	42.52	54	8.1	7.13	5.86	0.3	3000	3
F20-Y3	43	56	9	7.13	5.86	0.3	3000	3
F20-F1	35.56	49.068	5.2	9.92	8.37	1	3000	30
F20-F2	35.58	49.1	8.13	9.92	8.37	1	3000	30
F20-F3	35.56	49.068	8.13	9.92	8.37	1	3000	30
F25-Y1	45.212	61.35	9	15.51	14.44	0.5	3000	12
F25-Y2	45	61.35	9	15.51	14.44	0.5	3000	12
F25-Y3	48	63	9.5	15.51	14.44	0.5	3000	12
F25-Y4	55	72	10	14.76	13.18	0.5	3000	7.5
F25-F1	45.212	61.334	6.3	12.88	11.56	1	3000	50
F25-F2	45.212	61.334	9.015	12.88	11.56	1	3000	50
F32-Y1	58.928	79.95	11.81	15.51	14.44	0.5	3000	1
F32-F1	58.928	79.748	8.64	20.22	19.15	1.2	3000	90
F32-F2	58.928	79.748	11.81	20.22	19.15	1.2	3000	90
F40-Y1	71.12	98.171	14.47	26.4	25.67	0.6	3000	25
F40-F1	71.12	98.171	14.475	34.51	33.51	1.5	3000	200
F45-Y1	79.4	110.4	16.28	26.4	25.67	0.8	3000	25
F50-F1	88.9	122.71	18.09	34.7	34.94	1	3000	45

型号	内径	外圈	宽度	额定动负荷	额定静负荷	最大径向变形量	输入转速	输出力矩
Bearing	Inner ring	Outer ring	Width	Dynamic load	Static load	Radial Deformatio	Input rotate	Output torque
Model	ID	OD	B	Cr	Cor	Max. mm	r/min	N.m
MTHBT-3								
MTHBT-5	9.8	13.026	2	1.2	1	0.15	3000	1.5
MTHBT-8	14.22	19.63	3.1	2.8	2.4	0.15	3000	5
MTHBT-11	20.73	27.262	4.6	3.51	3.1	0.2	3000	6
MTHBT-14	25.07	33.896	6.095	4.74	3.75	0.2	3000	8
MTHBT-17	30.3	41.722	6.16	7.12	5.83	0.3	3000	16
MTHBT-20	35.56	49.073	7.24	9.93	8.36	0.3	3000	30
MTHBT-25	45.212	61.341	9.015	12.89	11.55	0.4	3000	50
MTHBT-32	58.928	79.756	11.81	22.28	20.91	0.5	3000	120
MTHBT-40	71.12	98.171	14.475	29.02	28.95	0.6	3000	250
MTHBT-45	79.476	110.434	16.287	36.15	35.1	0.8	3000	400
MTHBT-50	88.9	122.707	18.085	45.03	46.09	1	3000	450
MTHBT-14D	25.07	33.896	3.95	4.74	3.75	0.2	3000	8
MTHBT-17D	30.3	41.722	4.6	7.12	5.83	0.3	3000	16
MTHBT-20D	35.56	49.073	5.2	9.93	8.36	0.3	3000	30
MTHBT-25D	45.212	61.341	6.35	12.89	11.55	0.4	3000	50
MTHBT-32D	58.928	79.756	8.64	22.28	20.91	0.5	3000	120
MTHBT-14M	25.07	33.896	6.095	5.53	4.73	0.2	3000	12
MTHBT-17M	30.3	41.722	6.16	8.31	7.35	0.3	3000	24
MTHBT-20M	35.56	49.073	7.24	12.63	12	0.3	3000	45
MTHBT-25M	45.212	61.341	9.015	16.4	16.58	0.4	3000	75
MTHBT-32M	58.928	79.756	11.81	27.19	28.18	0.5	3000	180



Deceleration principle

The principle of harmonic gear transmission deceleration is to use the relative motion of the flexible gear, rigid gear and wave generator (mainly the controllable elastic deformation of the flexible gear), to realize the motion and power transmission. The elliptical cam in the wave generator rotates in the flexible gear, causing the flexible gear to deform. When the flexible gear teeth and the rigid gear teeth at both ends of the long shaft of the elliptical cam in the wave generator enter the engagement, the flexible gear teeth at both ends of the short shaft are disengaged from the rigid gear teeth. For the teeth between the long shaft and the short shaft of the wave generator, the half meshing state that is gradually entering into the meshing along the different parts of the circumference of the flexible gear and the rigid gear, is called meshing and the half meshing state that is gradually disengaging is called engaging-out. The continuous rotation of elliptical cam in wave generator makes the flexible gear deform constantly, which causes the teeth at the flexible gear and rigid gear to shift between the states of engaging-in, meshing, engaging-out and disengagement, thus realizing motion transmission from active wave generator to the flexible gear.

Wave generator

Assemble thin-wall ball bearing component in the periphery of elliptical cam. Inner wheel of the bearing can be fixed on the cam and outer wheel can perform elastic deformation through ball. It is usually installed on output shaft.



Flexible gear

The flexible gear is a thin-wall cup-shaped metallic elastic component and gears are carved on the periphery of its opening part. Flexible gear bottom (cup-shaped bottom) is called diaphragm part, which is generally installed on the output shaft.

Rigid gear

It is a rigid ring component and gears are carved on the inner ring. The number of the gears is two more than that of flexible gear. It is commonly fixed on the machine shell.

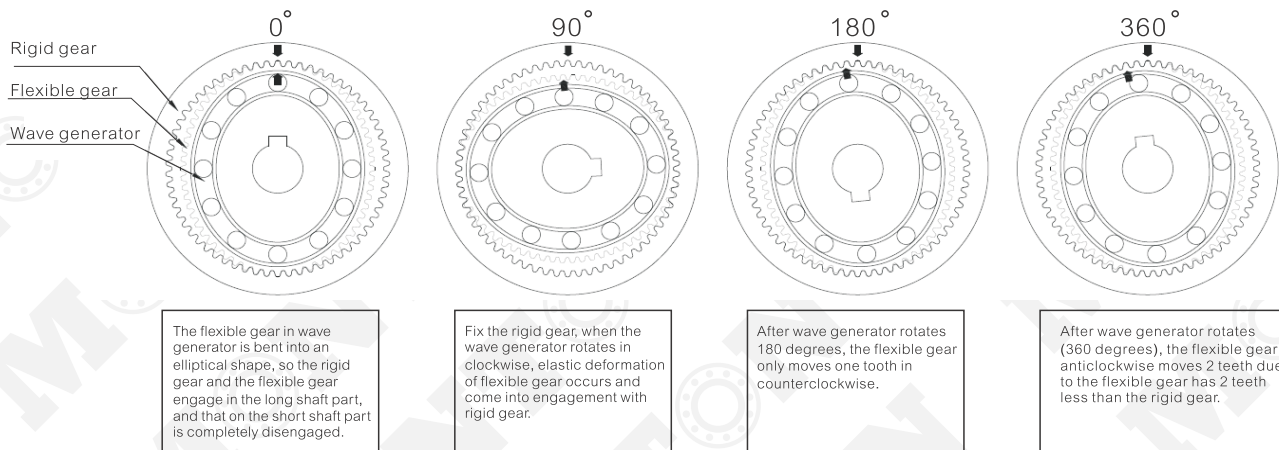

洛阳盟拓轴承科技有限公司

Luoyang Monton Bearing Science & Technology Co.,ltd.

河南省洛阳市建设路119号 471000

No.119 Jianshe Road,luoyang,Henan,China 471000

www.montonbearing.com

www.monton-bearings.com

电话Phone:+86 13213631171

Email:Sales@montonbearing.com